

ebs | kumkeo

SMART ENGINEERING

PROJECTS AND PRODUCTS FOR
MEASUREMENT AND CONTROL TECHNOLOGY

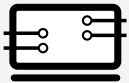



ELMAR

REAL-TIME FRAMEWORK
developed by e.bs kumkeo

Cut the number of electronic control units with ELMAR. The ELMAR framework is a real-time architecture for AMD® Zynq® UltraScale+™ MPSoCs that enables the operation of low latency closed-loop algorithms (optionally on the basis of Simulink®) parallel to **embedded Linux** distribution. A lightweight hypervisor ensures a distinct separation between Linux management and the application on the basis of an **RTOS**. Linux offers a web server, parameter administration, a firmware update mechanism and further features that simplify field administration of the board. In-house developed inter-core communication (ICC) provides synchronized communication between the ARM® cores for real-time applications.

Top features

Powerful, embedded control platform

Designed for lowest latencies and hard real-time conditions

Flexible framework for control applications

Performance

With our **kernel patch** specially designed for the AMD Zynq UltraScale+, we guarantee stable **10kHz inter-core communication** between the real-time cores. This is verified using a complex industrial Simulink® control algorithm.

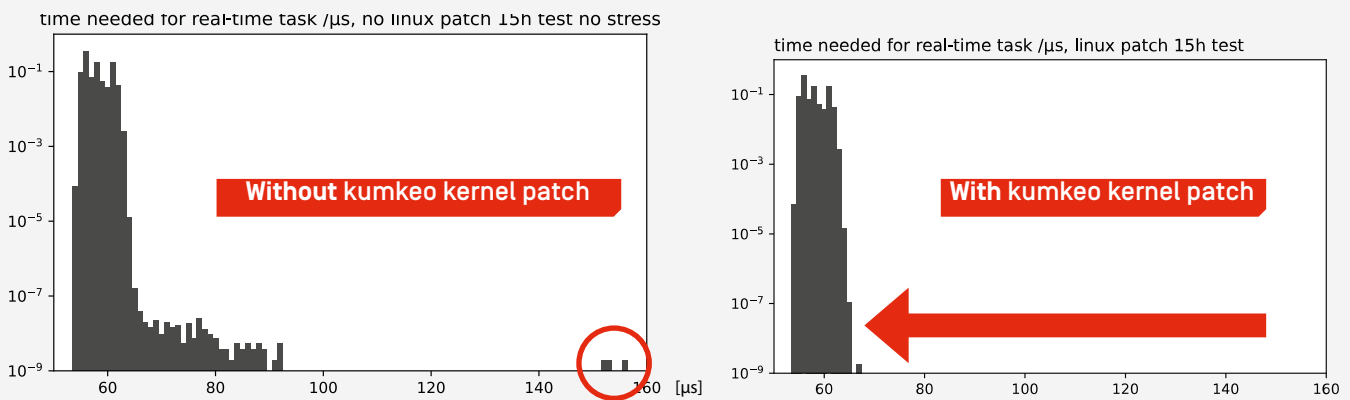

Architecture

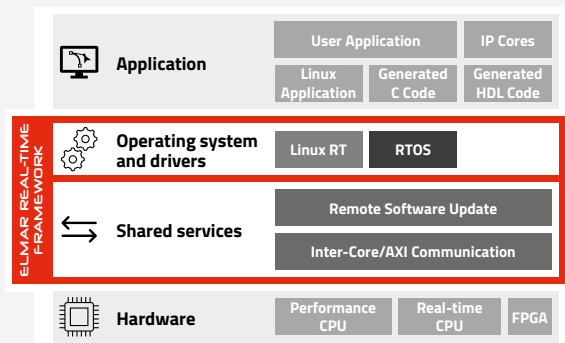
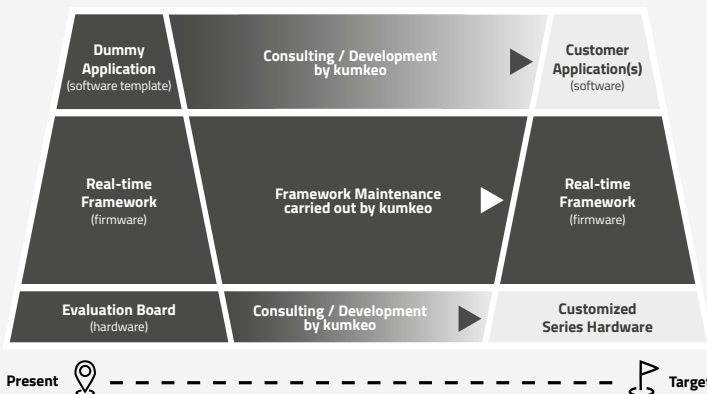

Overview of specific features

- INTER-CORE COMMUNICATION MECHANISM**
Synchronized communication of the process image between the ARM® cores on the basis of configurable and prioritization-capable channels.
- VIRTUAL NETWORK AND PRIORITIZATION**
Option to use a single IP interface outwardly for all ARM® cores. Prioritization according to EtherType via priority queues.
- PARAMETER MANAGER**
Centralized parameter management in Linux. Editable via web interface or primary controller. Persistent storage on SD card.
- HW AND SW WATCHDOG**
Configurable watchdog for real-time cores and Linux. Logging of reset reason.
- CENTRALIZED LOGGING AND EVENT LOGGING**
Central logging of all ARM® cores through syslog in Linux. Expandable to include configurable event messages.
- SCALABLE**
Our framework runs on all versions of the AMD® Zynq® UltraScale+™ MPSoC series, e.g. AMD® KRIA boards.

- REMOTE SOFTWARE UPDATE**
Remote controllable A/B update mechanism: signing and encryption support. Automatic rollback in case of error.
- SIMULINK® TARGET**
Use of a dedicated Simulink® target to support the real-time cores. Complete integration into Simulink®; no need to use VITIS®. Supports external mode.
- WEBSERVER UND IOT SUPPORT**
Provision of a web server and REST-API. Touch-optimized web interface for system information and configuration. Ready to connect to cloud/IoT platform.
- SECURE BOOT**
Optimal protection against compromised software through the use of Secure Boot.



ELMAR
EVALUATION BOARD
>>>
Block diagram

Your benefits

- TURNKEY FRAMEWORK FOR INTEGRATING AN APPLICATION**
Our real-time framework is immediately available and primed for integration of your application. The framework encompasses an example application that can be used as a template.
- COMBINES THE BENEFITS OF BOTH ENVIRONMENTS**
Isolation of Linux from the real-time cores through the use of a hypervisor means that the advantages of both operating systems can be exploited in parallel. Hypervisor latency is <math><3\mu\text{s}</math>.
- PREQUALIFIED AND DEPLOYABLE EVALUATION BOARD**
Our evaluation board is immediately available and can be used as a development platform or within test benches, prototypes and small batch production.
- FRAMEWORK MAINTENANCE CARRIED OUT**

- BY KUMKEO**
We continually enhance our real-time framework and make updates available in regular cycles. In the case of security patches, we provide a rapid response.
- FOCUS ON CORE COMPETENCIES**
While you concentrate on developing your application, we undertake the development of and any necessary adjustment to the real-time framework and also support you in a consulting role throughout the entire process.
- EXPERIENCE GAINED THROUGH WORK IN THE FIELD**
Our real-time framework is already in productive use in a sector industrial application and is currently being rolled out in series.

YOUR CONTACT

Alexander Baumann

PROJECT MANAGEMENT LEAD, PMP



Supported by:



on the basis of a decision by the German Bundestag

More information about ELMAR



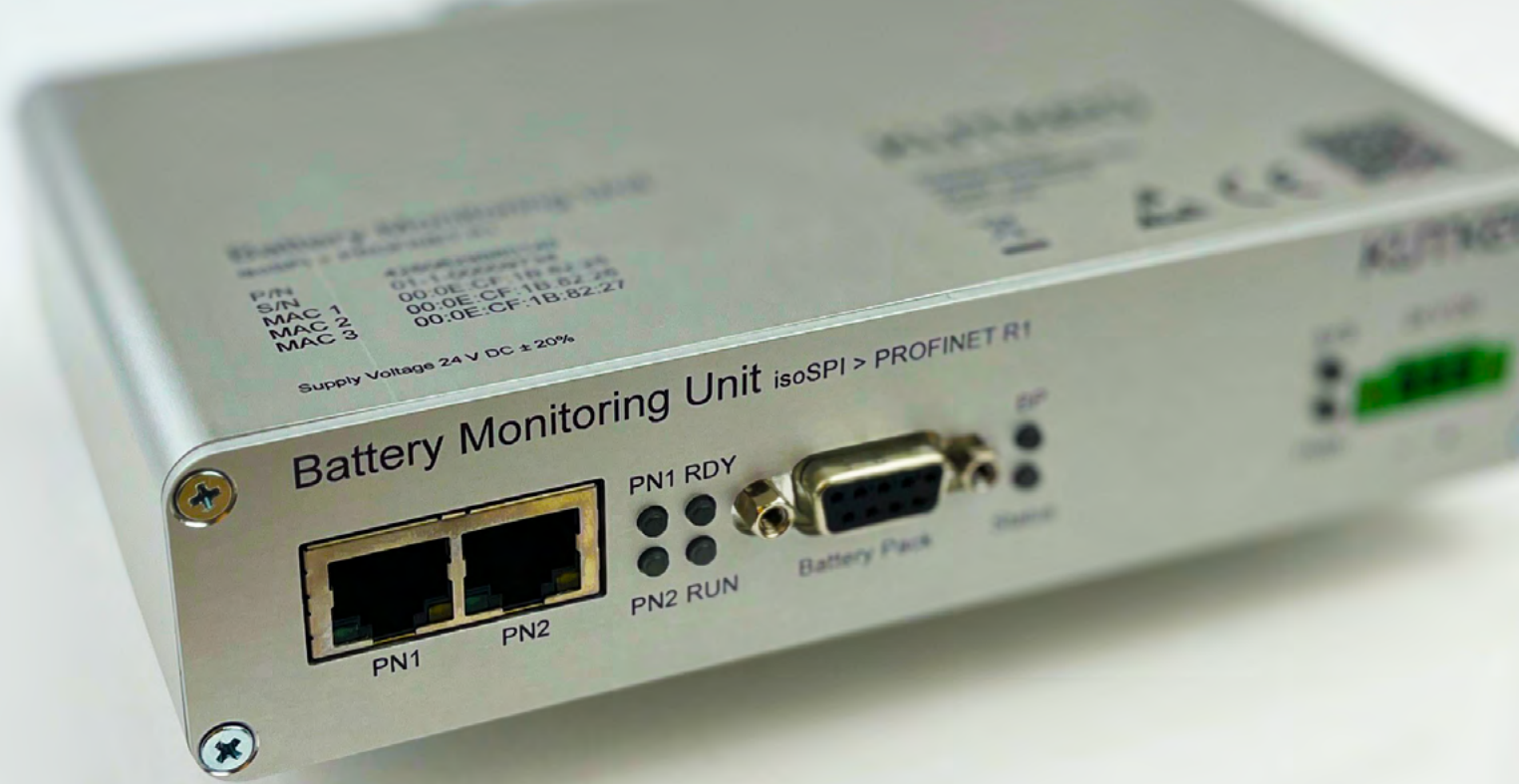

ENERGY SYSTEMS

Modern energy systems are the backbone of our sustainable future. They integrate renewable energy sources such as solar and wind power to reduce CO₂ emissions and protect the environment. Applying its technical expertise in the development of battery and battery management systems, kumkeo GmbH provides customized solutions for efficient energy storage to effectively support the sustainable and reliable energy supply of tomorrow.

Currently available are various configurations of the BEN energy system in a variety of voltage classes, capacities and cell chemistries for the real-time monitoring and analysis of battery data.

Your benefits

- +** **VERSATILE APPLICATION OPTIONS**
Scalable for a broad range of voltages and capacities.
- +** **FUTURE-PROOF**
The customization capability of the BMS ensures that future requirements can be met as technologies and use cases evolve.
- +** **SIMPLE EXPANSION**
Additional batteries and system components can be added with ease to meet growing requirements.
- +** **OPTIMIZED ALGORITHMS**
Battery life and performance maximized through customized algorithms.
- +** **MODULAR DESIGN**
Modular hardware and software design that enables simple expansion and customization.
- +** **MULTI-PROTOCOL COMPATIBILITY**
Supports multiple communication protocols (e.g. CAN, PROFINET, PROFIsafe) to enable a comprehensive range of applications.
- +** **HIGH-RESOLUTION MONITORING**
High-resolution monitoring of cell parameters for a more detailed insight and greater precision in terms of management.
- +** **TEMPERATURE MANAGEMENT**
Integrated, intelligent temperature management for enhanced performance and safety.

BEN OM01

BATTERY MONITORING SYSTEM

developed by e.bs kumkeo

The **BEN OM01 Battery Monitoring System** comprising a battery monitoring unit and balancer board, enables real-time monitoring and analysis of battery data, including voltage, temperature and state of charge, to provide a detailed insight into battery performance. Over 10,000 installed systems are safeguarding critical applications in the renewable energy sector.

Battery Monitoring Unit – top features

Monitoring of battery parameters

Calculation of charging current

Calculation of state of charge [SoC]

Calculation of battery state of health [SoH]

Fault and critical condition reporting

PROFINET communication with central controller



BENOM01
BATTERY
MONITORING
UNIT
>>>
Data sheet

Balancer Board – top features

Data acquisition of up to 18 battery cell voltages and 4 temperature sensors

Compensation of battery cell voltage differences [balancing] with up to 100 mA

Daisy chain isoSPI communication to BMU and other balancers

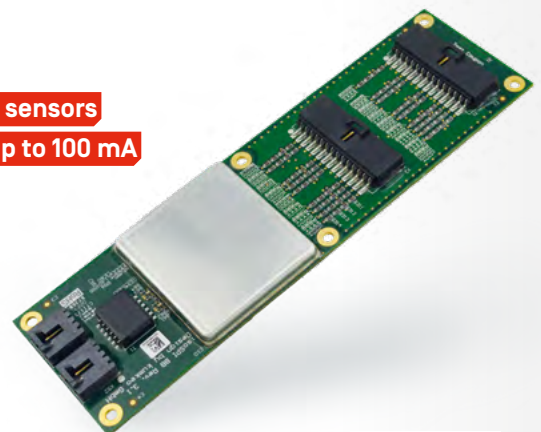

BENOM01
BALANCER
BOARD
>>>
Data sheet



More information about or BEN Battery Monitoring System

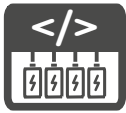

BEN

BATTERY MANAGEMENT SYSTEMS

developed by e.bs kumkeo

The **BEN Battery Management System** is a subsequent development of the Battery Monitoring System and was developed to provide optimal flexibility when adapting to different cell chemistries, cell interconnection capacities and voltage classes without compromising on safety. This is achieved through modularization of the **Battery Control Unit, Battery Disconnect Unit and Cell Monitoring Unit**.

Three versions are currently available featuring different voltage classes, capacities and cell chemistries.

BEN BM01

BATTERY MANAGEMENT SYSTEM

developed by e.bs kumkeo

614.4 V LFP 12.8 Ah

BEN EB01

BATTERY MANAGEMENT SYSTEM

developed by e.bs kumkeo

540.0 V NMC 81.2 Ah

BEN EB02

BATTERY MANAGEMENT SYSTEM

developed by e.bs kumkeo

537.6 V LFP 100.0 Ah

Top features

Surge voltage resistance up to 6.4 kV

Can be used at working altitudes of up to 4,000 m

Battery Management System architecture

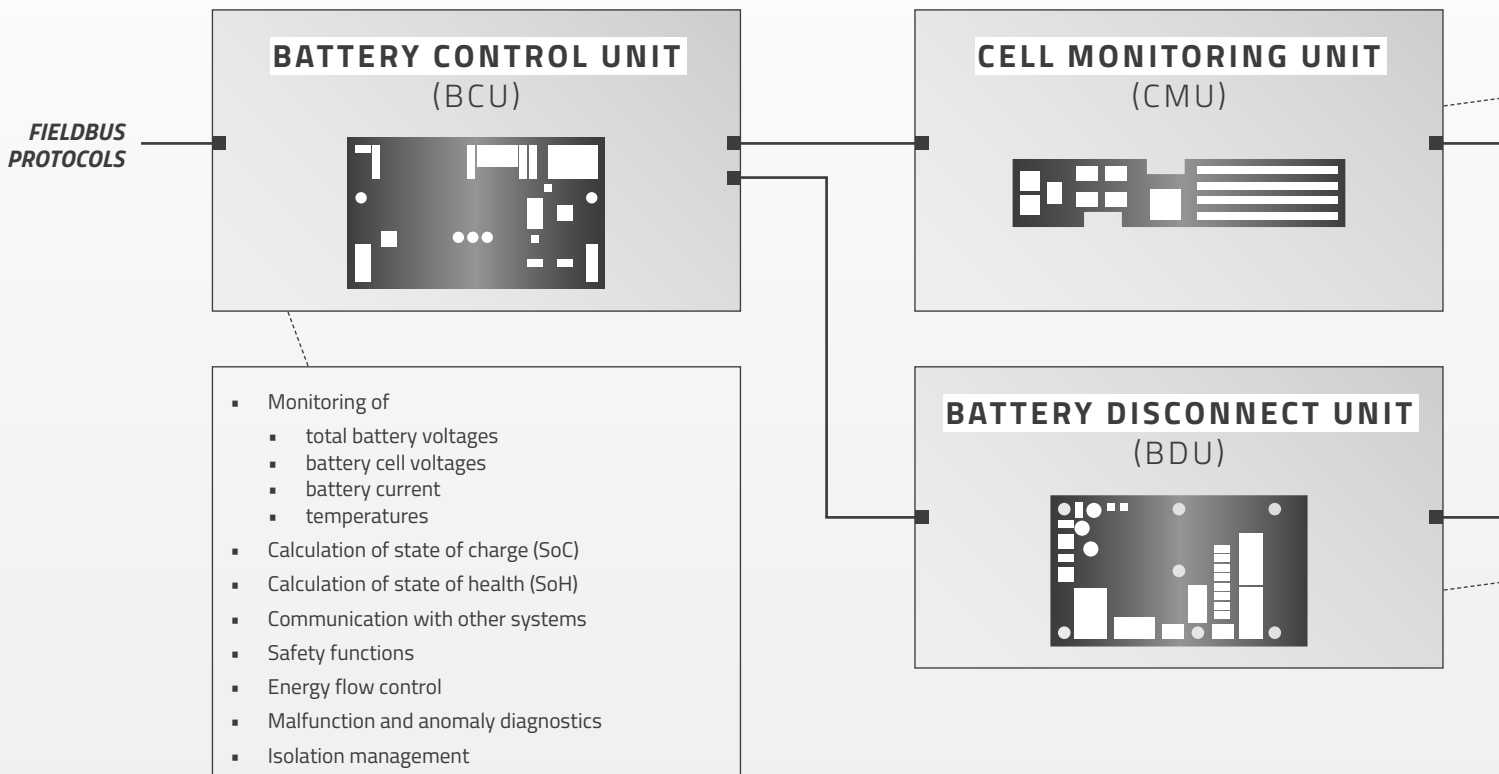



BEN

BATTERY SYSTEM

developed by e.bs kumkeo

In addition to the development of battery management systems, kumkeo GmbH also develops its **own batteries** in collaboration with leading partners. Such cooperation facilitates customized energy storage solutions that harmonize perfectly with BMS technologies. This combination of technical expertise and partnerships results in **reliable and efficient battery solutions** that will help shape the sustainable energy supply of tomorrow.

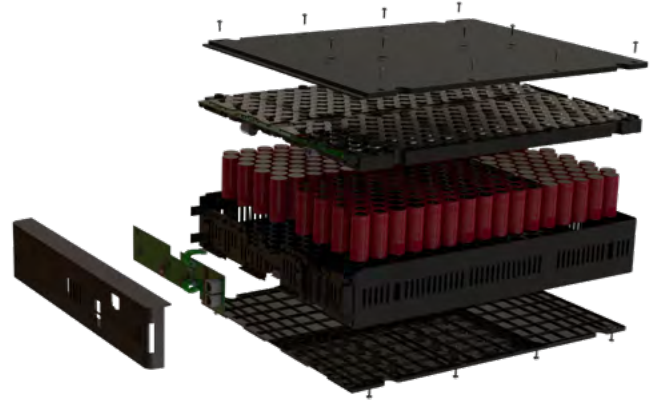

- Measurement of
 - cell voltages
 - temperatures
- Battery cell balancing
- Communication with BCU
- Measurement synchronization
- Energy saving mode
- Self-diagnostics
- Isolation management

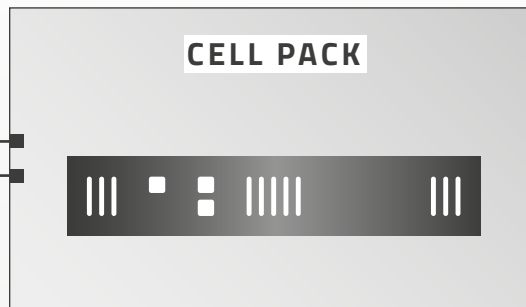

- Battery switching
- Overcurrent protection
- Short circuit protected
- Fault protection
- Contactor protection
- Battery total voltage and current measurement
- Communication with BCU
- Isolation management

- Power supply
- Cell connection
- Cooling and heat dissipation
- Structural integrity
- Isolation management
- Modularity and maintainability
- Environmental stability
- Weight and spatial efficiency

More information about our BEN Battery Management Systems





PAT

PROTOCOL CONVERTER

developed by e.bs kumkeo

Our high-performance **PAT Protocol Converters** are based on a scalable netX 90 platform. Using this multiprotocol SoC allows us to develop protocol converters for a broad range of applications within short development cycles.

Top features

Shorter development cycles due to an adaptable platform

Fast customization of all interfaces possible

Maintenance-free, designed for continuous operation

DIN-rail installation



BiSS-Gateway



PAT Bi-PS
PROTOCOL CONVERTER
developed by e.bs kumkeo

The **BiSS-Gateway** facilitates the connection of up to two sensors that implement the BiSS safety protocol. Data received is provided by the BiSS gateway to a PLC via PROFINET and PROFIsafe. This enables more abundant and precise data to be made available with fewer sensors. The outcome is longer and optimized application operation at a lower cost.



PATBiPSGW
PROTOCOL
CONVERTER
BISS-GATEWAY
>>>
Data sheet

EnDat-Gateway



PAT ED-PS
PROTOCOL CONVERTER
developed by e.bs kumkeo

In addition to the BiSS-Gateway, the EnDat 2.2 > PROFINET/PROFIsafe version of the **EnDat-Gateway** is also now up and running. In this version, the data received via EnDat 2.2 from up to two sensors or actuators are made available to a PROFINET IO Controller via PROFINET and PROFIsafe.



PATENPSGW
PROTOCOL
CONVERTER
ENDAT-GATEWAY
>>>
Data sheet

Supply Voltage 24 V DC \pm 20%

BiSS-Gateway 24 V BiSS Safety > PROF



PN1

PN2

PN1 RDY

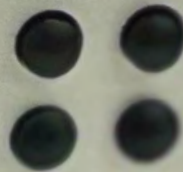

PN2 RUN



BiSS ON

Maximum compatibility and flexibility: Our PAT Protocol Converters seamlessly and effortlessly connect your systems and protocols.

More information about our protocol converter



ABOUT US

Applying future-proof technologies, we develop **smart solutions** for you with passion and commitment. Competence, an appetite for risk and innovation are at the very core of our mission. Our **market-driven flexibility** enables us to recognize and creatively exploit potentialities. Through agile and targeted collaborative work, we take a smart approach to create **sustainable added value** for you.

kumkeo was established in Hamburg in 2009. Our facilities are specially equipped for implementing **highly sensitive projects** and meet Federal Office for Information Security (BSI) requirements. We also constantly invest in the measurable quality and security of our services.

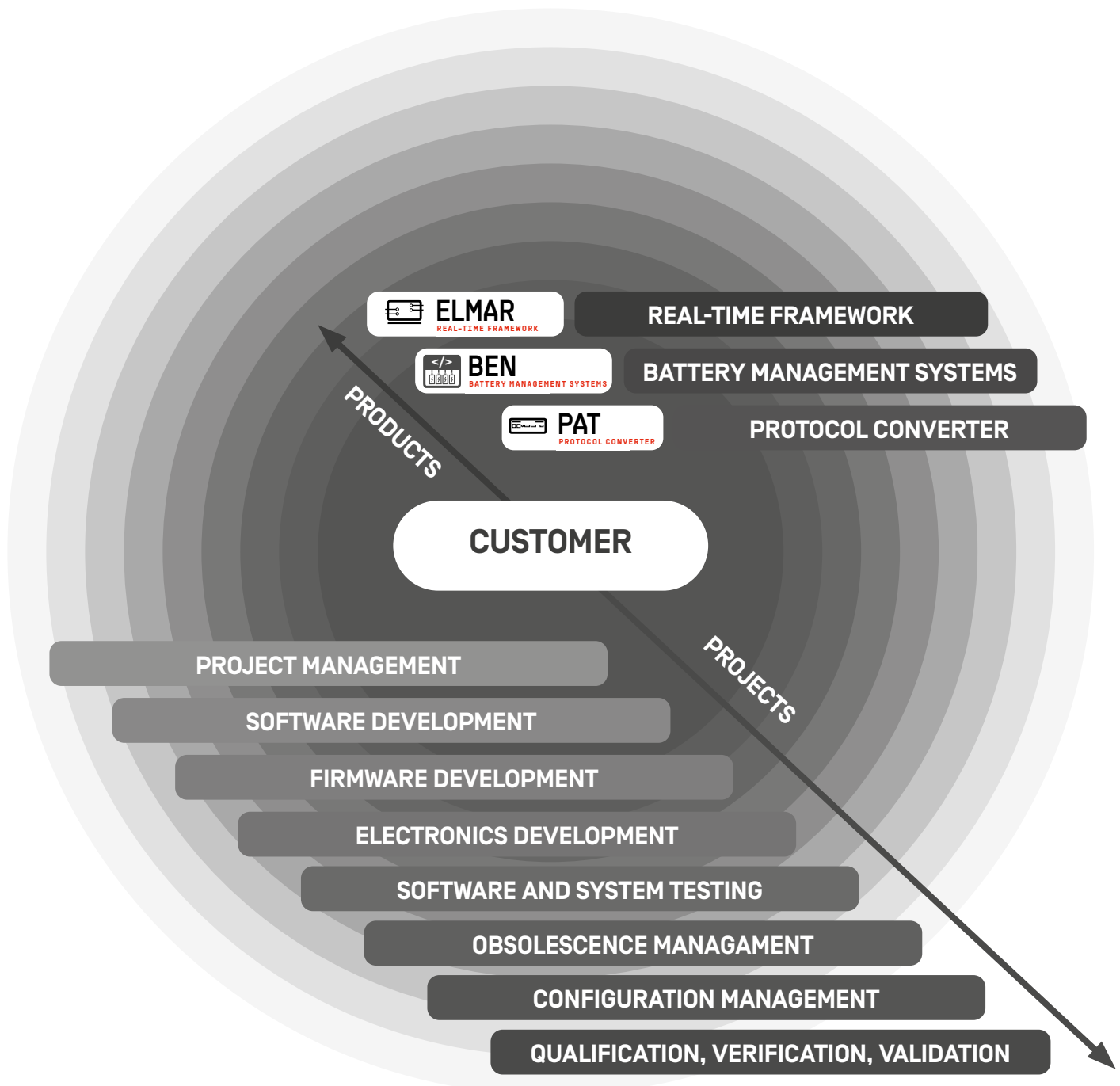



OUR PROMISE

At e.bs kumkeo, our primary focus is on you, the customer. Our very first discussion will quickly provide you with a clear insight into the quality of our work. We steadfastly realize your visions and assume responsibility for your development projects from the outset. Our practical concepts support you throughout the project planning phase and every phase of implementation, always fully in line with your specific requirements and under application of our sound expertise. kumkeo offers you a great deal more than just technical performance. Through experience gained in countless projects and our crystal clear and efficient communication, we work in close cooperation with you to develop optimal solutions.

We are there for you - always



DIPL.-ING.

Bernd Sager

CHIEF SALES OFFICER



DIPL.-ING.

Alexander Müller

CHIEF TECHNICAL OFFICER



DIPL.-ING.

Michael Schenk

TECHNICAL LEAD



M.SC.

Alexander Baumann

PROJECT MANAGEMENT LEAD

More information about us



e.bs kumkeo GmbH
Heidenkampsweg 82a
20097 Hamburg, Germany

Phone +49 40 28467610
E-Mail info@kumkeo.de

e.bs kumkeo GmbH
Am Kiel-Kanal 1
24106 Kiel, Germany

kumkeo.de ↗

e.bs AG
Sebastianstraße 13
6850 Dornbirn, Austria

Scan or click
to get more
information →
